

**Viega Drainage Technology  
for Bathroom and Floor.**

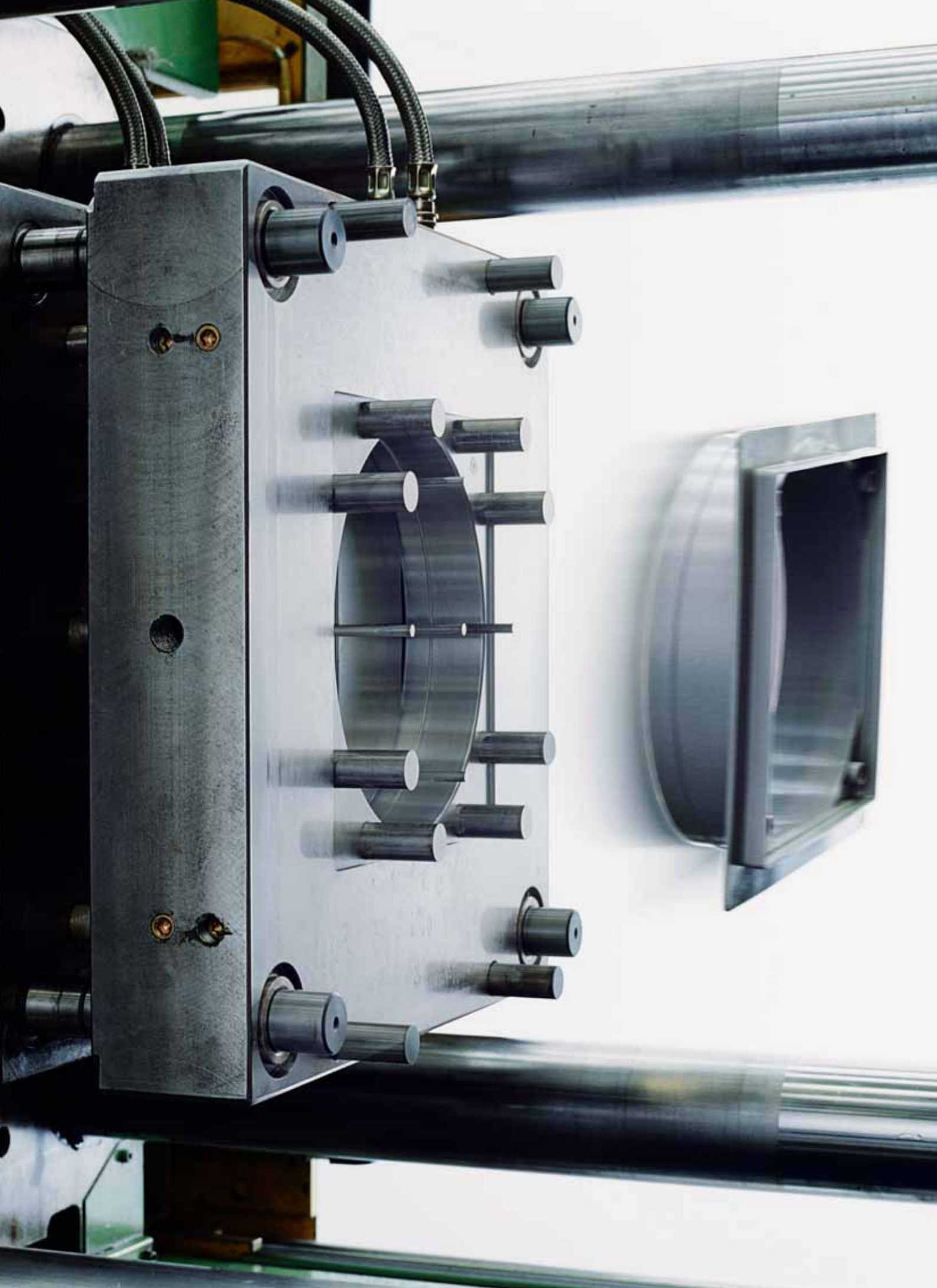



# Viega. A better idea!

## Family Tradition

The name Viega stands for a family company which set high standards from the word go. Product quality, client proximity, reliable delivery and service performance – all these standards are imposed company-wide. One thing is for certain: you need more than a good idea to compile an international success story. Courage, delight in innovation and passion are that qualities that, for good reason, have shaped the company for more than 100 years.

## International Success

Drainage technology is among the areas where Viega has set standards over many years. Bath or shower trays, drains, overflows and siphons made by Viega were established worldwide and installed a million times over. And for good reason, Viega is convincing as much for its technical as for its design quality. Numerous products were already awarded international design prizes.

## Systematic and Precise

Viega not only has a permanent stock of drainage technology products. A total of over 16,000 items are available, being selected, coded, packed and dispatched using an efficient logistics concept. The system is in place – as for everything at Viega. Not only are our processes integrated, but also our products. The best example is Viega's drainage technology, as featured here: a multi-faceted range of high-value detail solutions to define top modern bathroom design. True to our mantra: Viega. A better idea!







**Bathtub Fittings**

Inlet, outlet and overflow fittings, also with electronic control, which sparkle with modern technology and prize-winning design. Page **6**

**Washbasin Drain Valves**

Versatile universal- and slotted drains, optionally with or without click technology. Page **19**

**Odour Traps**

For washbasins and the secure connection of devices: perfectly thought-out, height-adjustable concealed and visible variations. Page **20**



**Shower Tray Drains**

The shower drain technology for extremely high drainage capacity and various installation conditions Page **12**

**Floor-level Drains**

Viega offers a wide selection of individual design possibilities. Page **22**

**Washbasin Siphons and Odour Traps**

Exclusive designer solutions, developed for the creation of sophisticated bathrooms. Page **16**

**Areas of Application and Installation Recommendation**

With Viega Advantix, we offer an ideal and assemblyfriendly solution. Page **30**



**Viega Drainage Technology:  
Good News for the Bathroom  
and Floor.**



**As perfect as they look:  
Bathtub Inlet, Outlet and  
Overflow Fittings.**





### Outstanding!

Beautiful design impresses everyone – even top-class design juries. No wonder then that the Visign Multiplex M3 and M4 fittings and fixtures together with the Multiplex Trio MT3 and MT4, among others, were awarded the reddot award 2006 and that Visign M3 also received the accolade “best of the best”. As a result, Viega remains true to its reputation as a design specialist for bathtub inlet, outlet and overflow fittings. Visign M3 and M4 are the systematic development of the successful classics, Visign M1 and M2. Irrespective of their individual design, all models provide inspiration through their form, function and variety.



M4/MT4



M3/MT3



M1/MT1



M2/MT2



Simplex



reddot award  
product design



DESIGNPREIS  
2007  
NOMINIERT



product  
design  
award  
2007

DESIGN PLUS

# Bathtub Inlet, Outlet and Overflow Fittings



## Multiplex Trio

The fitting is available in three variations for a drain hole of 52 mm in diameter and is above the norm in terms of its drainage capacity.

The Multiplex Trio MT3 is inspiring both as a result of its flat tub structure of just



20 mm and its prize-winning design.

## Rotaplex Trio

The Viega Rotaplex Trio has a drainage capacity of up to 1.25 l/s, for a drain hole of 90 mm in diameter. There are two designs to choose from for different bath sizes.

The Rotaplex Trio can even be combined with design classics such as the RT1 using different functional units.

## Simplex Trio

The Simplex Trio is suitable for bathtubs with a 52 mm drain hole. Its drainage capacity is also above the norm and it is characterised by a flexible overflow pipe.

## Viega Pipe Interrupter

So that backflow water does not impact on the drinking water quality: the Viega pipe interrupter to connect the Multiplex Trio, Rotaplex Trio and Simplex Trio fittings.



**Multiplex Trio**  
Inlet, outlet and overflow fitting for bathtubs, standard

**Multiplex Trio**  
Inlet, outlet and overflow fitting for bathtubs, middle drain

**Multiplex Trio**  
Inlet, outlet and overflow fitting for bathtubs, special edition



**Rotaplex Trio**  
Inlet, outlet and overflow fitting for bathtubs with 90 mm drain hole, standard and middle drain

**Rotaplex Trio**  
Inlet, outlet and overflow fitting for bathtubs with 90 mm drain hole, special



**Simplex Trio**  
Inlet, outlet and overflow fitting for bathtubs with flexible overflow pipe



**Pipe Interrupter**



# Bathtub Inlet, Outlet and Overflow Fittings: Electronic Mixer Unit



## Multiplex Trio E

Multiplex Trio E is a fitting for bathtubs, which at the press of a button carries out the process of filling the bathtub. An electronically controlled mixer valve measures and controls the temperature as well as the flow rate and stops the inflow as soon as the pre-determined filling volume has been achieved. The Multiplex Trio E can be combined with all Viega inlet, outlet and overflow fittings. When positioning the control element, either on the edge of the bathtub or the wall, you can decide freely how you like it. There is an extra assembly set available for wall mounting, consisting of a built in socket, fastening material, sealing collar and chrome-plated cover. All of the mixing technology can be placed freely and out of sight. It remains accessible via a revision duct.



### Multiplex Trio E Control Unit

For positioning on the bathtub edge or on the wall



### Multiplex Trio E Mixer Unit

For flexible assembly, even in confined spaces

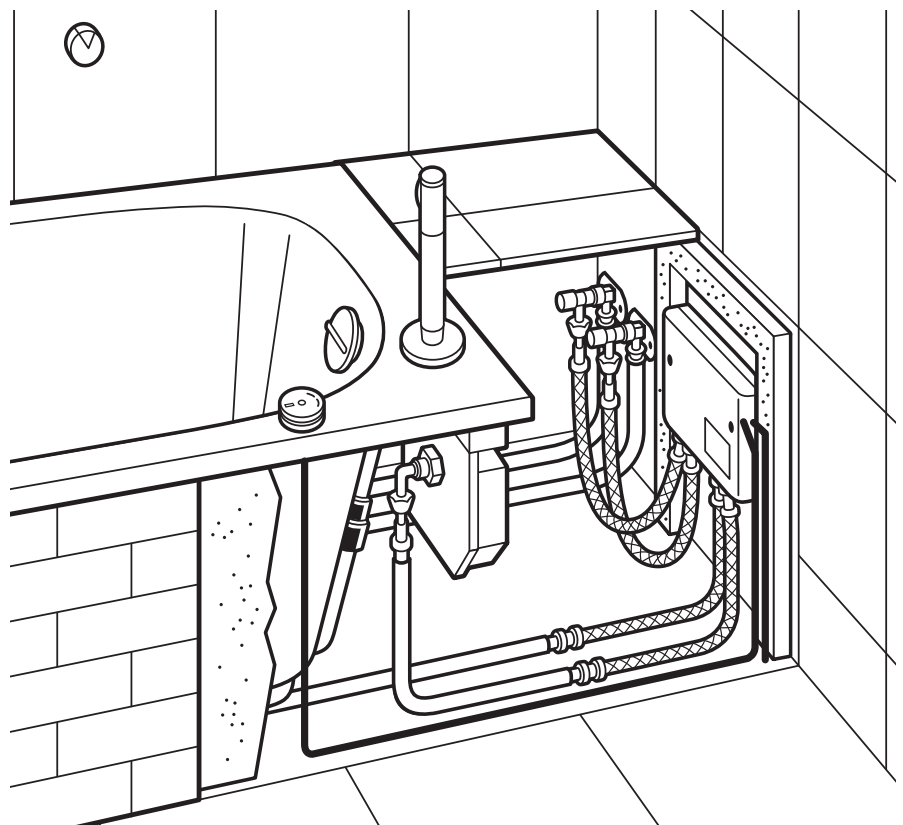

# Bathtub Inlet, Outlet and Overflow Fittings



**Multiplex Trio F and Rotaplex Trio F**  
 Multiplex Trio F and Rotaplex Trio F are inlet, outlet and overflow fittings for bathtubs. The water to fill the bathtub flows from the floor – almost silently: results of tests carried out by the Fraunhofer institute in Stuttgart show that the Rotaplex Trio F reduces the sound of filling the bathtub by more than half.

## Multiplex Trio F and Rotaplex Trio F

### Drainage Capacity

at an accumulation height of 300 mm  
 Multiplex Trio F                    **0.85 l/s**  
 Rotaplex Trio F                    **1.0 l/s**

### Overflow Capacity

at 60 mm accumulation height via middle overflow hole                    **0.63 l/s**

### Inlet Capacity

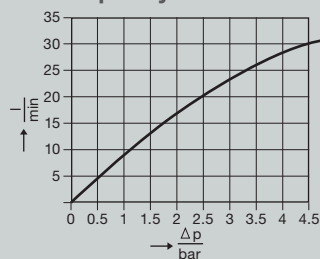

With an assembly height of 110 mm, Multiplex Trio F and Rotaplex Trio F require very little space. Inlet and outlet are clearly separated from one another by height difference. A backflow preventer ensures that no water is able to flow into the drinking water system. Further protection is provided by the concealed DVGW certified pipe interrupter which is included in the scope of delivery. In addition, both sets can be combined with all the Viega designer rosettes which have won many awards.



**Multiplex Trio F**  
 Inlet, outlet and overflow fitting for bathtub and drain hole with 52 mm diameter



**Rotaplex Trio F**  
 Inlet, outlet and overflow fitting for bathtubs with 90 mm middle drain hole



Compact construction height of only 110 mm. The designer bathtub fittings can be installed in bathtubs with a wall thickness between 3 and 10 mm and 52 mm and 90 mm drain holes. The rosette cover is made of chrome-plated brass

# Outlet and Overflow Fitting for Bathtubs



## Multiplex

Multiplex is the tried-and-tested variation without water inlet function. It is intended for drain holes with a 52 mm diameter and can be installed easily thanks to its low installation height. And practical too: Multiplex systems which have already been installed can be fitted retrospectively with the prizewinning M3 and M4 Visign lines.



**Multiplex**  
Outlet and overflow fitting for bathtubs



**Rotaplex**  
Outlet and overflow fitting for bathtubs with 90 mm drain hole

## Rotaplex

The Rotaplex is designed for largescale drainage capacities and is suitable for tubs with a 90 mm drain hole. Like the Multiplex, the Rotaplex can be equipped with four different designer rosettes. The Rotaplex is available in two designs for different tub shapes.

## Simplex

This fitting is characterised particularly by its designer rosette. The Simplex is available in two lengths for different sized tubs with a drain hole of 52 mm diameter. It has a flexible overflow pipe and its drainage capacity is above the norm.



**Simplex**  
Outlet and overflow fitting for bathtubs with flexible overflow pipe

## Citaplex

The drainage capacity of Citaplex also clearly fulfils the standard. The standard model with bead chain and valve plug can be used in all tubs with a drain hole of 52 mm diameter. Also suitable for bathtubs with 52 mm drain hole: the outlet and overflow fitting with click technology.



**Citaplex**  
Outlet and overflow fitting for bathtubs



**Citaplex**  
Outlet and overflow fitting for bathtubs with 52 mm drain hole, rounder, flatter overflow-cover and click valve technology on the drain



**Accomplished Design, perfect  
Technology: Viega Drainage  
Technology for Shower Trays.**





### Pure Shower Enjoyment

More and more customers want waterfall showers and XXL showerheads, for which extreme amounts of water are typical. At the same time, they prefer particularly flat shower trays, which can only hold small amounts of water.

With the Tempoplex, Viega offers high-quality, well-designed shower tray drains, and whose drainage capacity is up to 100 % above the norm. The beautiful covers of the drains can simply be pressed on and guarantee secure positioning, thanks to the 3-point anchorage.



# Drains for Flat Shower Trays



## Tempoplex

The Tempoplex was developed especially for flat shower trays with a drain hole of 90 mm. The installation height is 80 mm, the drainage capacity with up to 0.64 l/s considerably exceeds the norm. So that the base plate remains accessible, all Tempoplex models have a removable odour trap. In addition, they are equipped with an easily removable plug, which makes cleaning the drain pipe simple and practical.



**Tempoplex**  
Drain set for flat shower trays with 90 mm drain hole



**Tempoplex**  
Vertical drain set for flat shower trays with 90 mm drain hole

## Tempoplex Plus

The Tempoplex Plus is impressive with its top-rate values of up to 0.85 l/s – more than 100 % above the norm. It is suitable for flat shower trays with 90 mm drain holes and is designed to be particularly efficient. Thanks to the double seal on the drain hole and a globe joint, flawless fitting is also guaranteed. Of course, the Tempoplex Plus has the easily removable plug.



**Tempoplex Plus**  
Drain set for flat shower trays with 90 mm drain hole and globe joint drain supports



**Tempoplex, 60 mm**  
Drain set for flat shower trays with 90 mm drain hole, 60 mm construction height

## New: Tempoplex 60 mm for renovations

With Tempoplex 60 mm, Viega offers a model with a construction height of only 60 mm. This drain has a good drainage capacity. Simultaneously, its installation height is extremely low – an enormous advantage when renovating.



**Tempoplex EX**  
Drain set for flat shower trays with 90 mm drain hole



**Hair sieve**  
Can be placed in the Tempoplex models (apart from EX)

# Drain for Deep Shower Trays



## Domoplex

The drain set for shower trays with 52 mm or 65 mm drain hole has a first class drainage capacity and thanks to its low construction height of 80 mm can be installed easily. The double drain seal ensures greater reliability. Domoplex is available with a vertical outlet or with a 45° drain bend. In both cases the outlet has a diameter of 40/50 mm.



**Domoplex**  
Vertical drain set for shower trays with 52 mm drain hole



**Domoplex**  
Vertical drain set for shower trays with 65 mm drain hole

## Duoplex

With this family-friendly drain, the water can reach a height of 90 mm due to an extendable standpipe. The pipe is pushed back in to allow the water to flow away.



**Duoplex**  
Vertical drain set for shower trays with 52 mm drain hole and extendable stand pipe

## Varioplex

Funktionalität and quality combined. There are various possibilities with the Varioplex drain set. E.g. it is available with a standpipe which allows the water to remain in the tub. Further versions of Varioplex are available with click valve technology or a sieve. The drain is fitted with an odour trap which can be turned through 360° and makes assembly much easier.



**Varioplex**  
Vertical drain set for shower trays with 52 mm drain hole, stand pipe



**Varioplex**  
Vertical drain set for shower trays with 52 mm drain hole with sieve



**Varioplex**  
Vertical drain set for shower trays with 52 mm drain hole and click valve technology

**Elegantly solved:  
Viega Washbasin Siphons.**

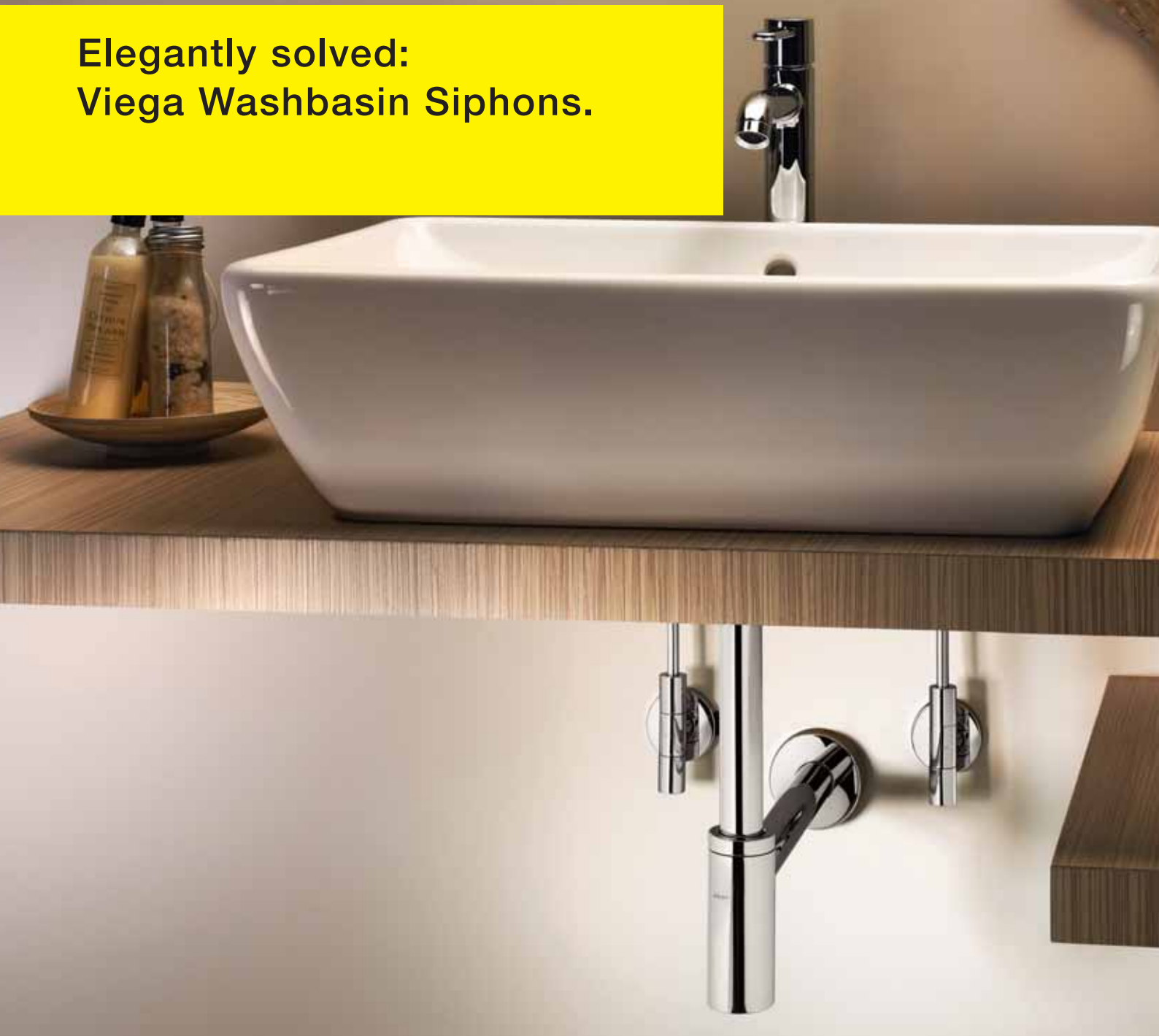





### Exclusive Design under the Washbasin

Actually, they are much too lovely to be hidden under the washbasin. The Eleganta washbasin siphons from Viega are one of the optical highlights in any bathroom, in outstanding quality and with amazing technology.

The Eleganta 1 with its lovely straightness, the Eleganta 2 plays with pleasing cones shapes, the Eleganta 3 focuses on organic curves. Each of the three Visign lines is inspiring with its fine details, such as the matching corner valves or the ability to be combined with Viega drainage valves.



Eleganta Set 1



Eleganta Set 2



Eleganta Set 3

# Washbasin and Bidet Siphons



## For a round Drain

The Viega washbasin siphons are inspiring as a result of both their design and tried-and-tested technology. Be it during assembly – through the large wall rosettes and long adjustable and drain pipes – or as a result of the integrated odour trap. Viega offers you a huge selection of siphons for washbasins and bidets for any bathroom. They can be integrated perfectly into the bathroom design with their shape and colour.



**Bottle Odour Trap**  
Brass, chrome-plated



**Bottle Odour Trap**  
Brass, chrome-plated, with universal valve and plug

## Material and Variations

Viega offers you the ideal siphon for your requirements to match your bathroom. Whether it is made of plastic or high-gloss chrome brass in bottle or pipe form, the siphons are inspiring with their efficient design and integrated odour trap. In addition, they are resistant to all household cleaners. For washbasins without overflow drains, Viega offers you a siphon with extendable stand pipe. This means a variable water level of 0–90 mm can be achieved.



**Pipe Odour Trap**  
Brass, chrome-plated, with universal valve and plug



**Bottle Odour Trap**  
Plastic, with universal valve and plug



**Odour Trap**  
Entirely chrome-plated, for washbasins without overflow hole. Standpipe can be extended by 90 mm



**Bottle Odour Trap**  
for Bidets, made of brass, chrome-plated

# Washbasin Drain Valve



## Extremely versatile

Whether round like Visign V1 or square cut like Visign V2, whether with or without an overflow function – Viega drain valves can be tailored completely individually as universal or shaft models to fit a huge variety of washbasin shapes. And anyway they are timelessly elegant.

## Amazing Click Technology

Viega universal and shaft valves are either unsealed or come with the practical click technology for water accumulation. By lightly pressing, these valves can be opened and closed. More evidence that Viega understands just as much about modern technology as it does contemporary design.

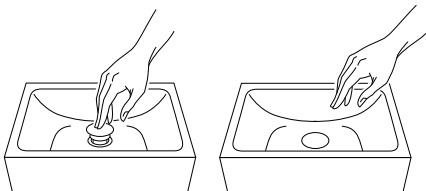

### Visign V1 Slotted Valve

Brass, chrome-plated with overflow function. With non-lockable cap or lockable via a round click-on closure cap



### Visign V1 Universal Valve

Brass, chrome-plated. With round, non-lockable cap or lockable via round click-on closure cap



### Visign V1 Slotted Valve

Brass, chrome-plated, with overflow function. Lockable via a round click-on closure cap



### Visign V2 Universal Valve

Brass, chrome-plated. With non-lockable cap or lockable via a square click-on closure cap



### Universal Valve

With sieve and stainless steel screw



### Universal Valve

With upper valve section and stainless steel screw, with screw plug

## Odour Traps for Washbasins



### Tried-and-Tested a million times

There are many reasons for the huge success of Viega odour traps. Their high drainage capacity is above the norm. Their effective internal workings allow for outstanding self-cleaning. And: the drainage elbow of the trap is screwed directly to the drain valve without the need for an additional adjusting pipe, which saves space.

### Material and Variations

The Viega odour traps are made of high-quality, environmentally-compatible polypropylene. It is resistant to waste water and to all normal household cleaners which makes Viega odour traps especially durable. Internally, the material also provides smooth surfaces. Viega odour traps are available as concealed (1) and exposed variations (2). The advantages can be seen in detail: the removable odour trap, the self-adjusting deal and the fact that no additional adjusting pipe is needed.

### Height adjustable

Viega odour traps are perfectly thought out. They are easy to fit, space-saving and offer a particularly intelligent function: they can be adjusted by 50 mm in height during final installation.



①

Odour trap, concealed version



②

Odour trap, visible version



Height adjustable by 50 mm at end installation



Compact shapes, combinable with various furniture washbasins and semicolumns



# Odour Traps for Washing Machines



## Odour Trap with integrated Water Inlet

To drain washing machines, Viega offers concealed traps with integrated water inlet. This means inlet and drain can be fitted in one procedure. As an alternative, these can be fitted behind the device in an easily accessible place for optical reasons. The backflow preventer and pipe ventilator are part of the shut-off valve fittings. Both are also integrated into the connecting elbow.



## Odour Trap without Water Inlet

If the trap is installed as a concealed model, then only the rosette and angled hose fitting are visible in addition, there is the space-saving option of visible assembly. The odour trap can be installed particularly quickly and easily with the joining material provided with the fitting.



Odour trap with integrated water inlet



Odour trap without water inlet



**Functionality and Beauty:  
Floor Drainage with  
Viega Advantix and Viega Visign.**

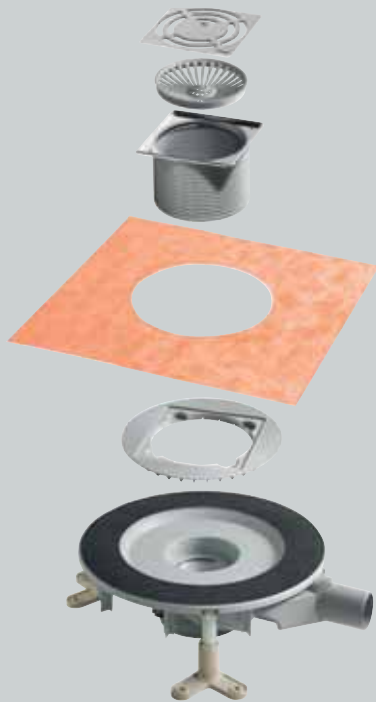

Viega Advantix is a well thought-out modular system for bath and floor drainage. From the design of barrier-free bathrooms to floor drains in public buildings through to the drainage of terraces, roofs and cellars. The most varying base plates, sealant versions, attachments and grates can be freely combined and coordinated exactly to the relevant application. The different components of the Advantix system all have one thing in common: their quality.

Visign grates by Viega round off the well thought-out Advantix modular system perfectly. Between the exquisite tiling and sophisticated tiled backsplashes, the high-quality design solutions provide a certain optical je-ne-sais-quoi. The range comprises a huge range of grates for shower channels, bathroom, floor and corner drains, which have already been awarded with several internationally recognised design prizes.



reddot award  
product design



DESIGNPREIS  
2008  
NOMINIERT



product  
design  
award  
2007

## Visign Grates for Advantix Shower Channels



### Convincing Design

No matter whether it's a design jury, builder or specialist tradesman – Visign grates for Advantix shower channels convince everybody. With original design, high-quality materials and intelligent technology, they offer excellent quality in every sense. They are made of stainless steel and can be combined with many other materials, e.g. glass or individual floor coverings such as tiles or natural stone. The grates are equipped with rubber cushioned adjusting screws. This means that annoying step and metal noises are almost completely prevented. And, naturally, the Visign grates can be combined with the Advantix shower channels as well as with the new frameless Advantix Basic shower channels.



Visign ER1



Visign ER2



Visign ER3



Visign ER4\*



Visign ER9

\*individually adaptable tile inlay



# Visign Grates for Advantix Bathroom, Floor and Corner Drains



## Visign Grates

Square grates for straight architecture, round forms for bathrooms with curved contours, corner drains in straight and round designs, as well as a huge variety of materials and perforations. With the high-quality Visign grates by Viega made of stainless steel or in combination with glass, individual design freedom knows hardly any limits.



Visign RS11



Visign RS2



Visign RS14



Visign RS4



Visign RS15



Visign RS5



Visign EA1



Visign EA11



Visign EA5



Visign EA15

# Viega Advantix. The Perfect Modular System



## Bathroom drains for small/medium drainage capacity

A selection from the complete range



The products shown on these pages are only a selection of the extensive Advantix product range.

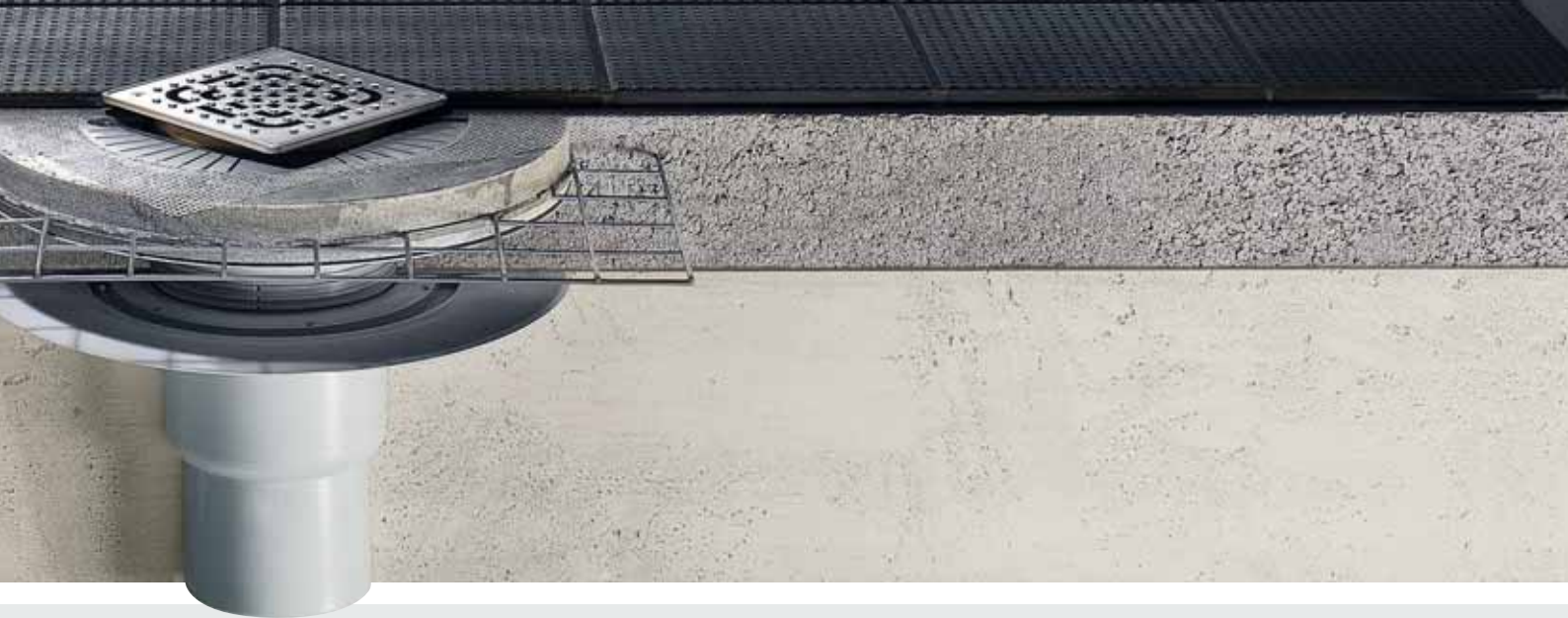

## Bathroom drains for higher drainage capacity

A selection from the complete range



4933.4



4933.2

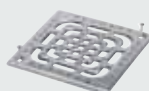

4933.6



4933.61



4929.1



4929.3



4976.21



4963.2



4963.4



4976.41



4922.5



4922.6



4922.7



4933.7



4933.71



4922.8



4949.3



4963

# 1

Attachments and Grates

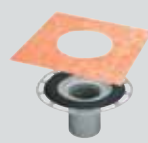

4994

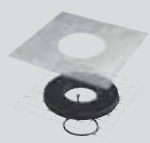

4954



4996.1

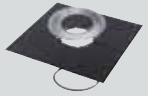

4998.3



4996

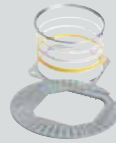

4954.8

# 2

Add-on Elements and Sealants

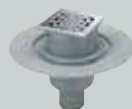

4951.1



4951.15



4955.1



4955.25



4955.15



4951.20

# 3

Base Plates



Viega Advantix Top:  
Extremely Effective,  
Extremely Variable,  
Extremely Backflow  
Secure

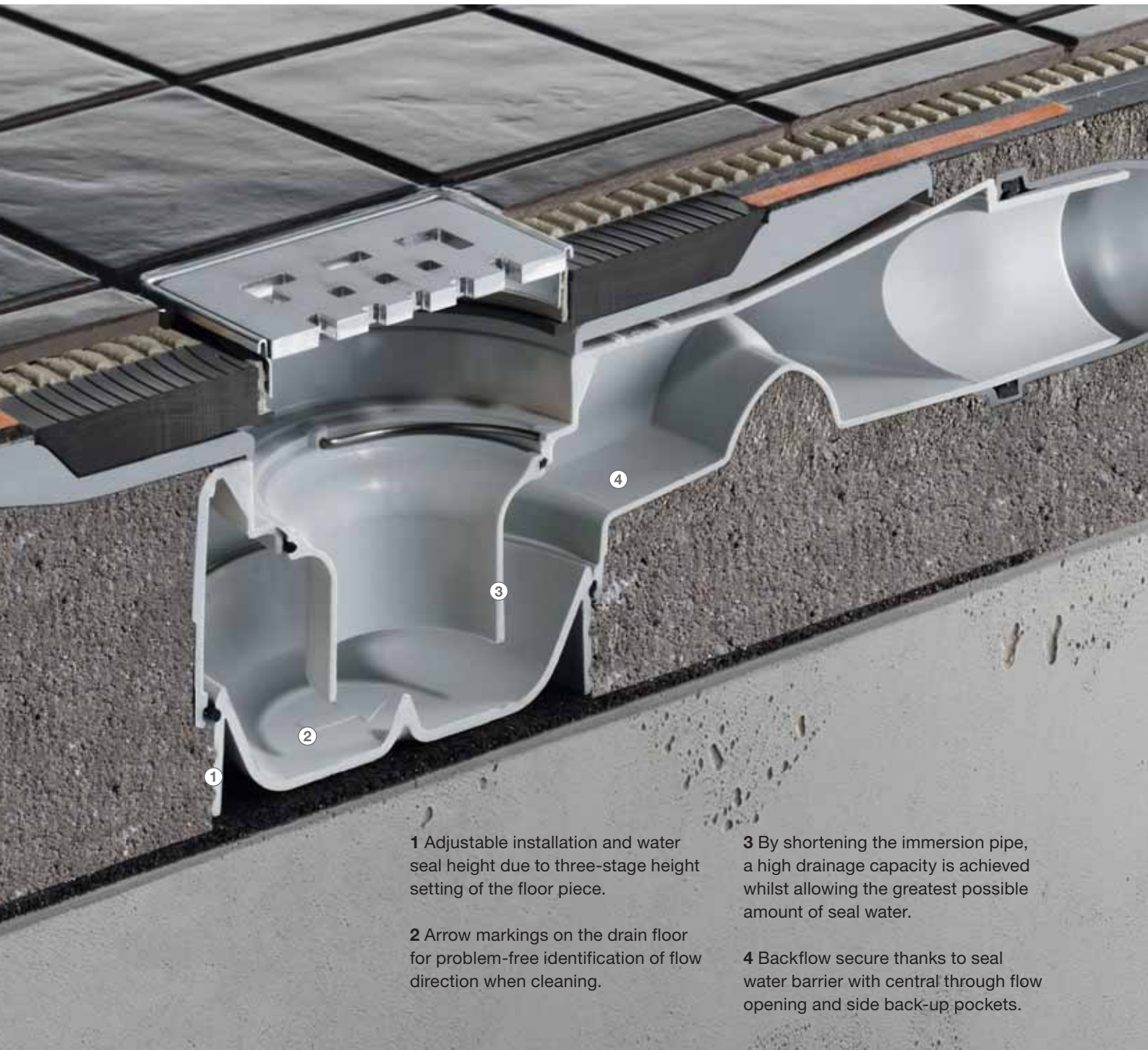

**1** Adjustable installation and water seal height due to three-stage height setting of the floor piece.

**2** Arrow markings on the drain floor for problem-free identification of flow direction when cleaning.

**3** By shortening the immersion pipe, a high drainage capacity is achieved whilst allowing the greatest possible amount of seal water.

**4** Backflow secure thanks to seal water barrier with central through flow opening and side back-up pockets.



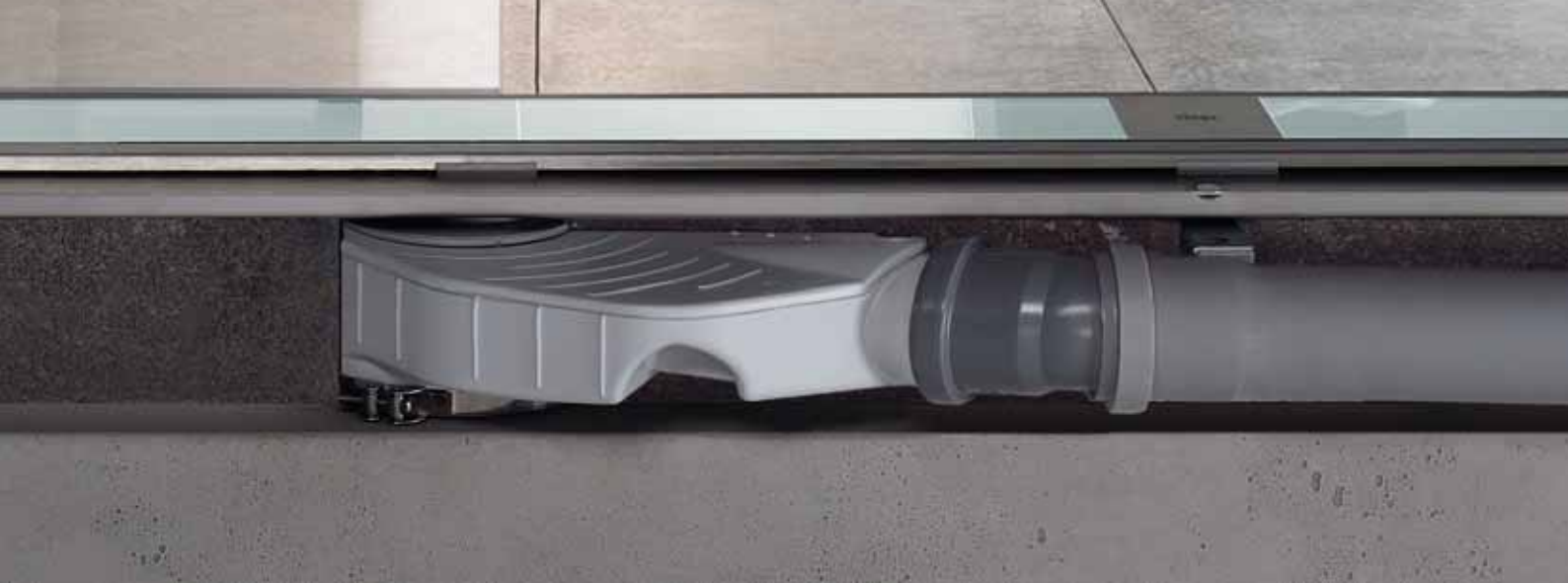

The trend towards floor-level showers in connection with increasingly lower floor heights has created the demand for floor drains with the characteristics “high capacity, flatter, more secure”. Altogether characteristics which, up until now, had been difficult to realize simultaneously. But now Viega offers the fitting solution: Advantix Top!

### The Function Principle

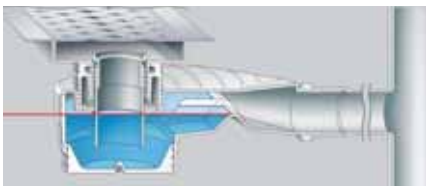

In normal operation conditions, the sealing water height is 35, 40 or 50 mm

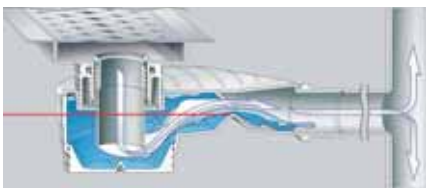

If a vacuum should occur in the system, then thanks to the back-up pockets, only a fraction of the sealing water will be sucked away

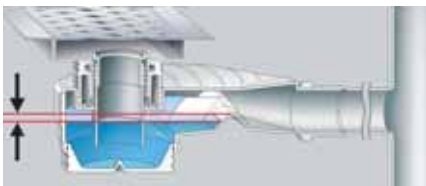

In that case, there will still be sufficient water in the drain for the odour trap

### High Capacity

Due to an optimization of the flow resistance and a more generous form, the new Advantix Top floor drain achieves a drainage capacity of up to 1.2 l/s.

### Variable

Advantix Top can be adjusted on site to a floor assembly height starting from 90 mm. By shortening or selection of the immersion pipe, depending on the model, the water seal height of 35, 45 or 50 mm is adjusted to suit the construction height.

### Backflow Secure

The suction pressure in the piping system ensures that due to a self-developed function principle there is always sufficient sealing water in the drain to protect against unpleasant odours. And that is even possible at a sealing water height of only 35 mm. Therefore, the requirements of DIN EN 1253 are fulfilled even at a low sealing water height.

### Flat Actual Construction Height, with 2 m Drop Included

To be able to keep the actual construction height as low as possible, drain supports were placed on the upper edge of the drain structure. Even in the flattest of installation conditions the height difference to the bare concrete of the floor is still 20 mm. A connecting pipe up to two metres long can be laid, without needing to lift the drain.

### Simple to Clean

To clean the drain cover, just remove the inserted immersion pipe. Even the connecting pipe can be cleaned using a spiral.



Advantix Top for shower channels and corner drains



Advantix Top for conventional sealing



Advantix Top for bonded sealing

## Advantix in the private Bathroom



### Advantix in the private Bathroom. The Foundation for Modern Bathroom Design

Barrier-free baths and floor-level showers demand an efficient drainage system. Advantix bathroom drains with a drainage capacity of up to 1.0 l/s for the flow of small to medium-sized water amounts are an outstanding choice here.

#### Advantix Shower Channels

Advantix shower channels from Viega are the perfect choice for floor level showers. They make it possible to have a continuous, straight incline in the bath which does not cause any unattractive diagonal incisions in the tiles. The base plates are available in lengths of 750–1200 mm and have a minimum construction height of just 85 mm. Another advantage: they can be placed anywhere in the room or along the wall.

#### Two Variations

Advantix shower channels are available in two variations: as a flexible variation with stainless steel grate frame – laterally and optionally also height adjustable; or in the economical Basic variation – laterally adjustable. All Advantix shower channels can be equipped with the prestigious Visign grates.



#### Highest Quality, Millimetre Precision

High-quality materials and careful preparation ensure a high level of stability of the Advantix Basic shower channel – the version for installation on the wall is shown here. Optional support feet help with the exact positioning. Maximum drainage capacity: 1.0 l/s



#### No Odour, more Flexibility

The version with double odour trap. Flat version, with a drain support, adjustable thanks to a ball joint. Maximum drainage capacity: 0.4 l/s

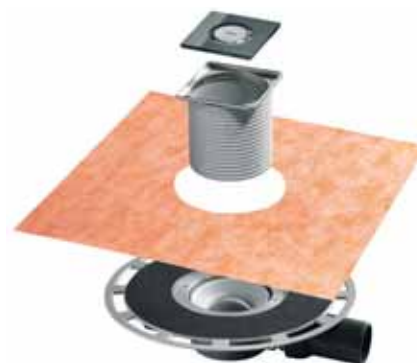

#### All inclusive

The complete package for floor-level showers. Shown here in the ultra-flat version, including a Schlüter-Kerdi sealing collar for an easy and secure installation. Maximum drainage capacity: 0.5 l/s

## Advantix on the Terrace



### Good Outlook for poor Weather: Viega Advantix on the Terrace

Irrespective of whether the balcony or terrace is tiled, has a gravel bed or support legs – Viega offers the right drainage technology for any type; if required, even with a second sealant level. Advantix drains have been developed for large amounts of precipitation and have norm-conforming and highly resilient grates. It is possible to retrofit the drains with an odour shut-off valve without water seal.

### Drains for unused Areas

The extensive Advantix programme by Viega also includes drains which are suitable for unused flat roofs and terrace areas. They have an overhead gravel and foliage catcher.



### For Terraces and Balconies with 2nd Drainage Level

The inlet element takes the water below the floor. The drainage capacity is 2.5 l/s; a combination with different add-on elements and attachments is possible



### For unused Flat Roofs and Terrace Areas

The solution with gravel and foliage catcher – available in nominal widths of DN 50, 70 and 100. Maximum drainage capacity: 4.5 l/s



### Quick and odour proof Installation

This version of the insert drain with frost proof odour trap is suitable for non-sealed floor constructions in terraces and outside areas. With the multiple lipped seal, the drain can simply be inserted into the existing pipe end. Maximum drainage capacity: 0.7 l/s

# Advantix for the Cellar



## Viega Advantix for the Cellar. The Basis of any good Drainage System

In work rooms, utility rooms and cellars, water often only occurs temporarily and in small amounts. High drainage capacities are normally not required. Depending on the use, additional seals can be avoided. However, there is naturally no reason for Viega to scrimp on quality for the cellar.

### Integrated Odour Trap

As well as complete drains with pre-integrated odour traps, Viega offers you the option of fitting floor drains with an odour trap later on.



#### Odour proof Installation

This version of the insert drain is suitable for use in the areas of the cellar where odours are especially undesired.

Maximum drainage capacity: 0.55 l/s

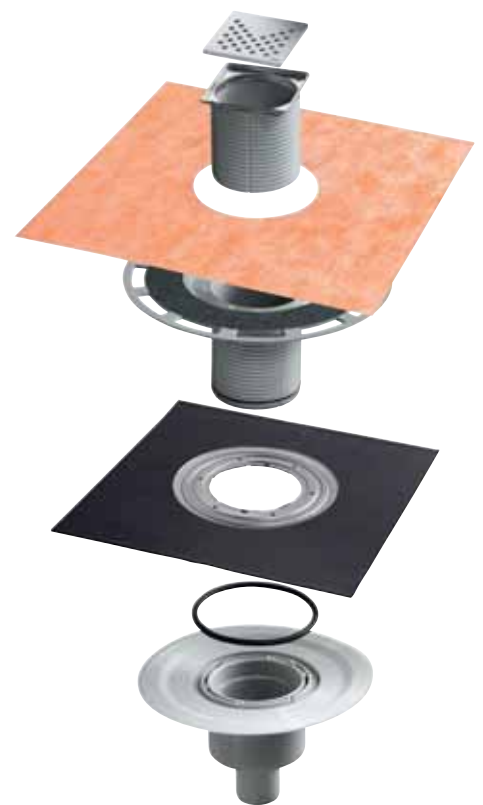

#### Ideal for Cellar Floors or Floor-Level Showers

Drain combination with two sealing levels (bitumen on concrete and bonded sealing below tiles) and vertical drain for the direct connection to the underground pipes. DN 100. Maximum drainage capacity: 0.9 l/s

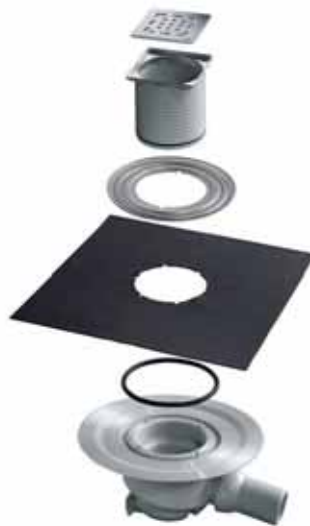

#### Large Amounts of Water possible

The drain with 50 mm water seal head. For areas, in which large amounts of water can occur at times.

Maximum drainage capacity: 1.1 l/s





## So that the Renovation flows perfectly.

With renovations, often only low installation heights are possible. For this reason, Viega offers ultra-flat drainage solutions, especially for renovating measures. For example, they can be used in and on wooden constructions or above concrete floors in floor screed.

### Ultra-Flat Bathroom Drain

The ultra-flat bathroom drain has an installation height of just 70 mm, but can be fitted extremely securely, as with all Viega floor drains. Fittings on the flange rim ensure especially stable anchorage in the floor screed. An additional sealant flange is used to absorb the liquid sealant. The supplied sealing collar provides additional security.

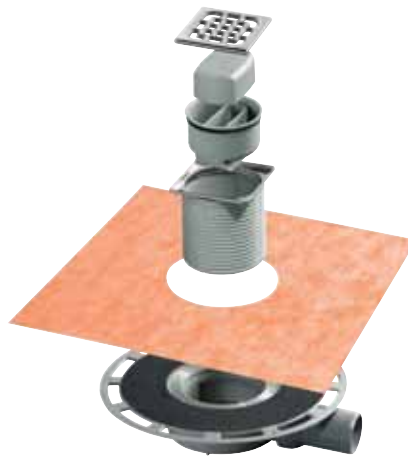

### Integrated Odour Trap

The ultra-flat drain combinations has a pre-integrated odour trap. It prevents unpleasant odours in the bathroom and can be retro-fitted. Maximum drainage capacity: 0.4 l/s



### For Conventional and unsealed Floor Constructions

The drain with a construction height of 75 mm and a drain support, which can be adjusted thanks to a ball-joint. Maximum drainage capacity: 0.6 l/s

### The All-rounder: Advantix Top

The qualities at a glance: high drainage capacity, backflow safe, casing and connection pipe easy to clean, sound-proof tested and stable supporting feet that can be screwed into the ground.

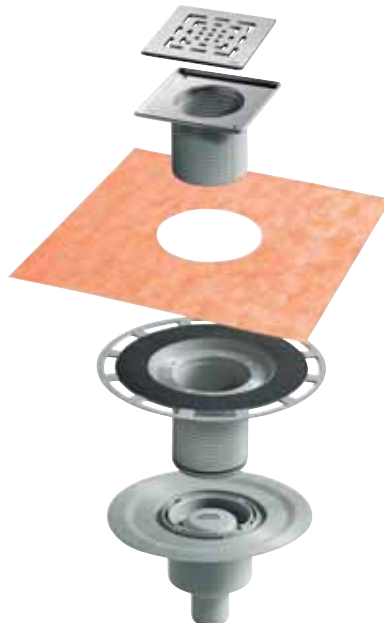

### Solution for floor level Showers with Pipe laying in the Basement

Vertical base unit with clamping flange for bitumen seal. Add-on element for bonded sealing technology with ultra-flat floor drain. Maximum drainage capacity: 0.9 l/s

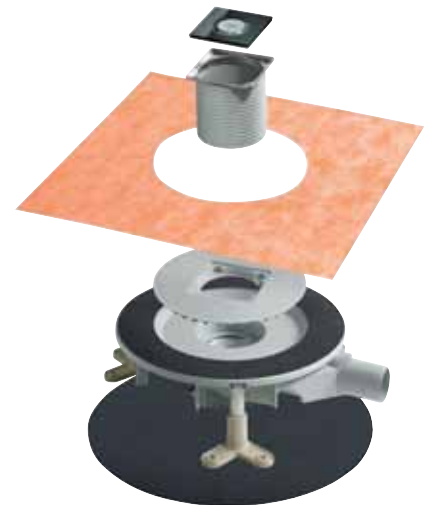

### Advantix Top for bonded Sealing

The drain unites a reliable assembly technology with all of the requirements to faced the demands placed on it by modern construction. Maximum drainage capacity: 1.2 l/s

# Viega Advantix. Plan with perfect Assembly and Fire Protection Properties.



## The Functioning of the Fire Protection Drain:



After 4 minutes, approx. 460 °C: the plastic pipe becomes malleable.



After 8 minutes, approx. 625 °C: the pipe is melted; the swelling mass fills the entire borehole.



After 25 minutes, approx. 800 °C: borehole and connection are completely sealed. The water trap remains largely in tact.



### Fire Protection Technology by Viega

When it comes to fire protection, Viega focuses on the ease of fitting together with uncompromising safety and absolute quality. Viega Advantix fire protection products R 120 are designed using state-of-the-art technology with a tested fire resistance of up to 120 minutes in order to prevent fire and smoke from spreading through the ceiling. In the case of a fire, a conventional drain made of plastic will melt within just a few minutes and an opening is created, which connects two storeys. For this reason, Advantix fire protection products have an integrated fire protection element. This element has an intumescent mass which completely swells up at temperatures above 150 °C and completely seals off the free profiles in the area of the ceiling duct.

### The In-Pipe Technology

The fire protection drain and the pipe lead-in can also be fitted using in-pipe technology. To do this, a PP or PVC pipe is cast during cut-out, in which the drain is later inserted – like a borehole. In the case of a fire, the swelling mass also fills out the slit which develops as a result of the melting pipe.

### Special Solution by Viega: The R 120 Pipe Duct

For fire-proof ceiling feed-through of shower basin drains or horizontal bath or floor drains, Viega offers a special solution: the R 120 pipe duct. This makes it possible to install a horizontal drain at a later point in time. So it can be positioned exactly under the shower or in the tiling pattern.

### Simple, Building Site-Compliant Fitting:



**1** The installation of the fire protection drain R 120 is completed in a few steps. After boring, a second borehole is created – approx. 20 mm deep in the ceiling. The concrete edge is chipped off.



**2** Then: apply mortar to the chipped ring and insert the pre-assembled fire protection drain.



**3** The flange must be flush to the ceiling. The spring fastener fixes the component. Then, fill the assembled drain with water and attach the protective cover. Attention: the fire protection is only guaranteed, when the odour trap is completely filled with water.



Viega Products  
for Bonded Sealing  
Technology





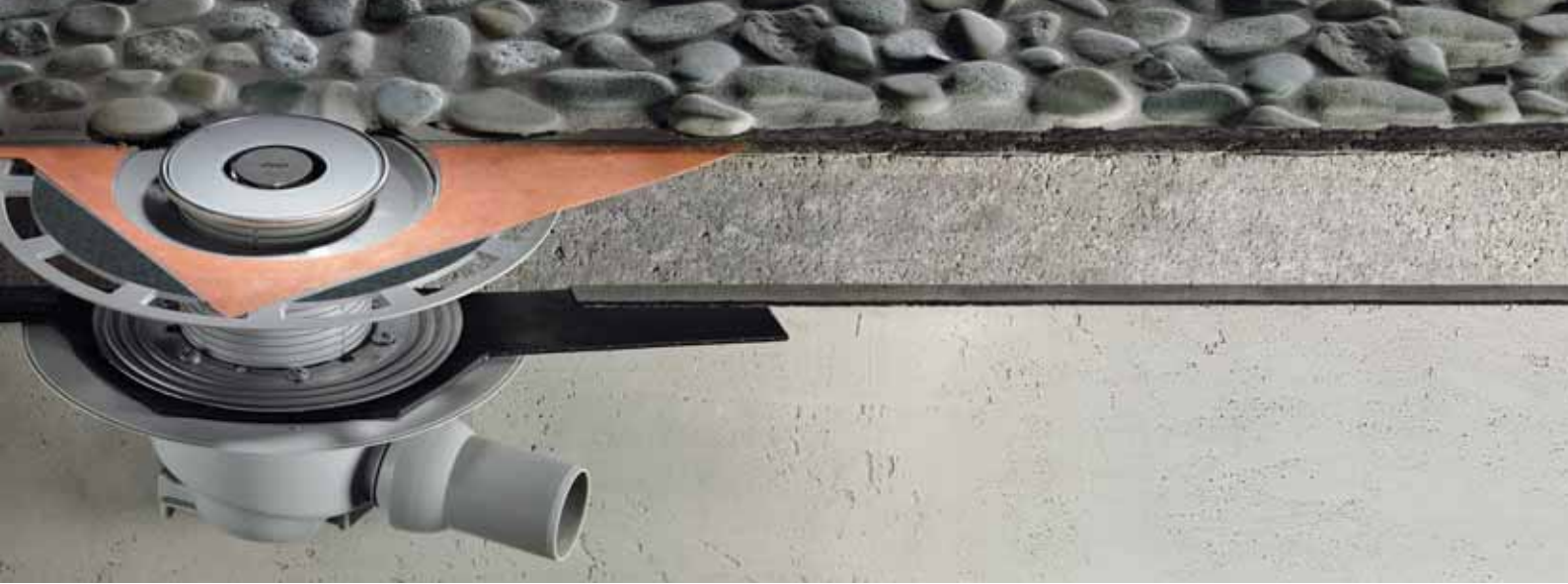

### The Advantages of Bonded Sealing Technology

Since the protection of the structure from moisture penetration has the top-most priority, bonded sealing technology is used increasingly for floor-level showers. The advantages: the seal between the floor screed and tiles prevents the floor screed from being penetrated by moisture. The use of bonded sealing technology saves any additional seals through bitumen or plastic channels.

### Double Reliability during Fitting

Because the main concern is the safe transition between the drainage area and floor screed, Viega counts on double reliability. Firstly, the special fitting of the flange anchors the drain securely into the floor screed. Secondly, the sealant collar provided with the fitting makes the transitional zone more secure. It is fitted directly into the liquid seal.

### Various Advantix Add-On Elements

Viega offers the right add-on element for every area. For commercial areas with high load strain or for outside, for example, add-on elements made of polymer concrete with cast steel grates and additional fibreglass matting – for floor constructions with low installation heights, add on elements made of plastic. And an ultra-flat drain for renovations.



#### The Fitting of Bonded Sealing Technology:

1 Remove protective foil.

2 Apply initial liquid surface sealant, e.g. by unrolling.

3 Insert the supplied Schlüter-Kerdi sealing collar into the still-liquid surface sealant.

4 Apply the second layer of surface sealant after the setting period.

5 After drying the seal, cut the attachment to size, insert and apply tile adhesive.

6 Lay the tiles. Important: Seam openings must not be sealed by the surface sealant or tile adhesive.



The new Viega  
Advantix Top.  
Perfect for all  
Assembly Conditions





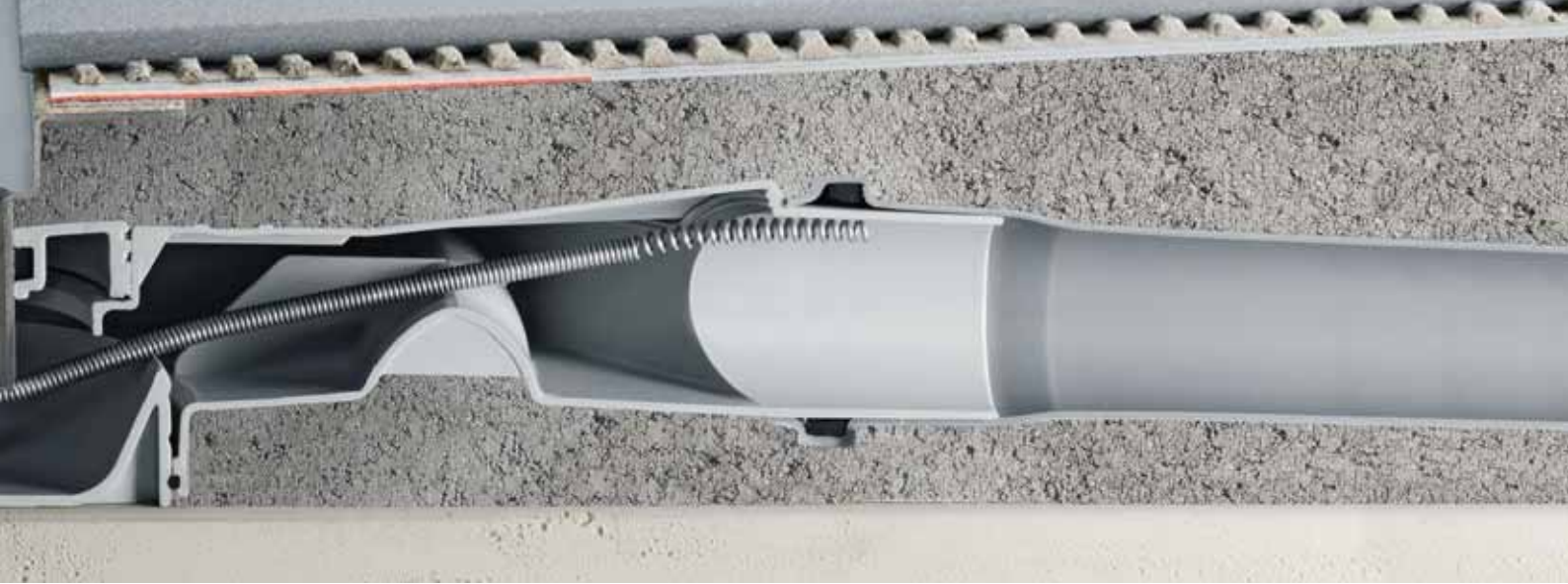

### The Drain with the Height-adjustable Floor

The new floor drain Advantix Top has a floor that is height-adjustable by up to 20 mm. Together with the assembly feet, which are also height-adjustable, it can be adjusted to any room situation and in the process of the pipe installation it can be secured both stably and securely on the underlying surface. Even just before screed laying, the drain can be finely adjusted.

### Well Thought Through

The base unit of the Advantix Top is supplied with two flange discs, which each allow the use of a 100 or 150 mm fixture. In addition, a soundproofing mat is also among the accessories. It allows a soundproof installation and compensates for subsequent recession of the screed. When it comes to Advantix Top, they thought of everything – even a bonded sealing flange with sealing collar. This is protected by a foil that is designed to shield the product from damage on site and is suitable for use with normal liquid foils. A further advantage: The cleaning process of the drain is particularly simple, all the way to the drain supports.

### High Drainage Capacity, even higher Level of Flexibility

Advantix Top convinces with an impressive drainage capacity. The 100 grate has a capacity of 0.8 l/s and the 150 model is 0.9 to 1.2 l/s, depending on the height of the fixture. Equally impressive: Even in the flattest installation condition, 20 mm above ground drain supports, an installation of approx. 2 m of piping with normal gradient is possible without raising the drain. The total construction height of the Advantix Top starts at only 85 mm.

#### The Installation:



1 Measure the floor construction height, here: 85 mm.



2 Adjust the height adjustable floor of the Advantix Top to the site conditions.



3 Choose one of the immersion pipes included in the scope of delivery, here: using the shortest model.



4 Position the drain and sound insulating mat and, and adjust it to exactly the right height, with help from the height-adjustable assembly feet.



5 Work in the Schlüter-Kerdi sealing collar into the liquid foil.



6 The perfect result: The Advantix Top floor drain with a construction height of only 85 mm assembled in a few steps.

Viega Advantix  
Shower Channels.  
Assembly and Sealing







### Floor Level Shower Channels

Viega Advantix shower channels are available in two variations: with adjustable stainless steel grate frames and as a frameless basic variation. Both are height adjustable and can be combined with all Visign grates for Advantix shower channels. Their maximum drainage capacity is 1.0 l/s, the seal water head is 35, 40 or 50 mm.



### Advantix Basic Shower Channels

The economical frameless basic variation of the Advantix shower channels emphasizes the used Visign grate, which fits in perfectly with the tile pattern. The sand coated flange provides optimal grip for all common sealing materials.



### Advantix Shower Channels

The framed variation of the Advantix shower channels connects design demands with increased assembly comfort. The stainless steel frame is laterally adjustable and via distance pieces also height adjustable. It also allows exact alignment in the tile pattern. Adjustable feet and sealing accessories can be ordered separately if required.

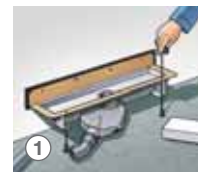

### Wall mounting Advantix Basic Shower Channel

1 Adjust the shower channel with help of the continuously adjustable screw feet.

2 Application of the Schlüter-Kerdi sealing tape in the liquid bonding material.

3 Tiling with or without covering edging rail up to the edge of the EPS hard foam block.

4 The perfect result: The frameless Advantix Basic shower channel with Visign grate. Built-in in a few steps.



### Floor Mounting Advantix Shower-Channel

1 Adjust the shower channel with help of the continuously adjustable screw feet.

2 Insert the shower channel into the bonded seal with the sealing accessories.

3 Adjust the height-adjusted grate frame from the middle by up to 5 mm. Then tile up to the frame.

4 The perfect result: The perfectly adapted Advantix shower channel with Visign grate.

Conventional  
Assembly







### Areas of Application for Conventional Sealing

Even with so-called conventional technology, building components such as ceilings, floors and even insulation can be permanently protected from moisture. The sealing channels made of bitumen or EPDM used for this procedure are applied directly to the unfinished concrete or thermal insulation. This technique has proven itself particularly in the sealing procedure for balconies, terraces, floor panels and cellar floors. In addition, conventional sealant channels can also be used as an additional second sealant level in a sealing procedure carried out with bonded sealing technology.

### Processing Variations

Viega drains can be incorporated with a clamping collar and a sealing collar either in bitumen or EPDM channels - without risk of damaging the drainage structure during welding or adhesive work. The fully developed technology of the Viega components guarantees safe transition between drain and sealing channel - irrespective of which processing variation is used.



### The Fitting of Conventional Sealing:

**1** The double-sided sealing collar (EPDM layer above, bitumen layer below) is laid over the drain and screwed on with the flange ring.

**2** Connection to a bitumen ceiling duct: ceiling duct is welded (open flame) and connected using subsequent treading down.

**3** Connection to a pure EPDM duct: EPDM duct is welded using a hot air gun and then connected by rolling with the sealing collar. Priming is no longer required.

Viega GmbH & Co. KG  
Plumbing and heating systems  
Viega Platz 1  
DE-57439 Attendorn  
Germany  
Phone +49 2722 61-1297  
Fax +49 2722 61-1146  
info@viega.com  
www.viega.com

